



Trusted by Professionals Since 1989



EGT-201

Full Height Turnstile

we make your world secure 🔑

EGT-201 Full Height Turnstile (single Lane)

Full height turnstile is a high-tech product which provides intelligent management to passageway. This full height turnstile with nice and elegant shape, antirust, durable, resistant to external damage. Very comfortable space for passage. Prevent illegal IN and OUT. Turnstile gate release during emergency. This product is suitable for stadium, prison, office building, government, confidentiality center. This gate can integrate into all access control systems.

Technical Parameters

- Housing material: SUS 304 Rotation angle: 120°
- Operation Voltage: AC220±10%V 50±10%HZ
- Working voltage: AC220±10%V 50±10%HZ
- Roof Dimensions : L1500*W1350*H2200 mm
- Height : 2200MM
- Direction: Single direction/bi-direction
- Working environment: Indoor/outdoor (with a tent over) -10°C~70°C
Relative humidity: ≤90% coagulation free
- Time of opening/closing: 0.2 second
- Pass speed: 20 persons/min
- Time to work after power on: 3 seconds
- Reset time after break down: 10 seconds
- Normal running life: 3.5 million
- Input interface: +12V level signal or pulse width>100ms 12V pulse, drive current>10mA

Standard Functions & Features

- Unique two-way anti-reverse function.
- Anti-rushing function, when the gate signal is not received, the turnstile arms locked automatically.
- The center rotor will be set free (default) or locked (optional) automatically when the power is off.
- Automatic Reset Functions: after you swipe the card, during the specific time (the system is 10s), if you didn't pass the turnstile, the system will cancel your access automatically, (reset time is 1~60s you can adjust it what time is suit for you)
- The turnstile can work with door access control system/ticket system/biometric recognition system.
- LED indicator light
- Can be unidirectional or bidirectional control of personnel access.

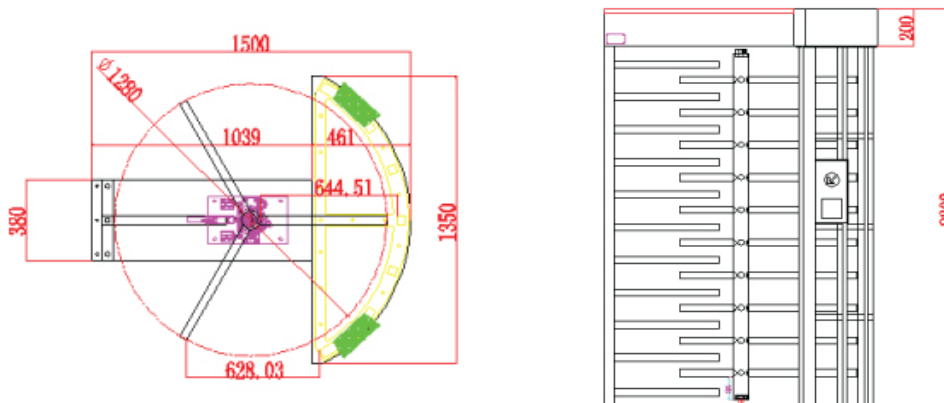

EGT-201 Diagram



For more information: Check out the website at www.elid.com, or contact our dealers. ELID has a policy of continuous research and development, and reserves the right to change specifications without notice.